

# Royal Express

## Operations & Maintenance Manual

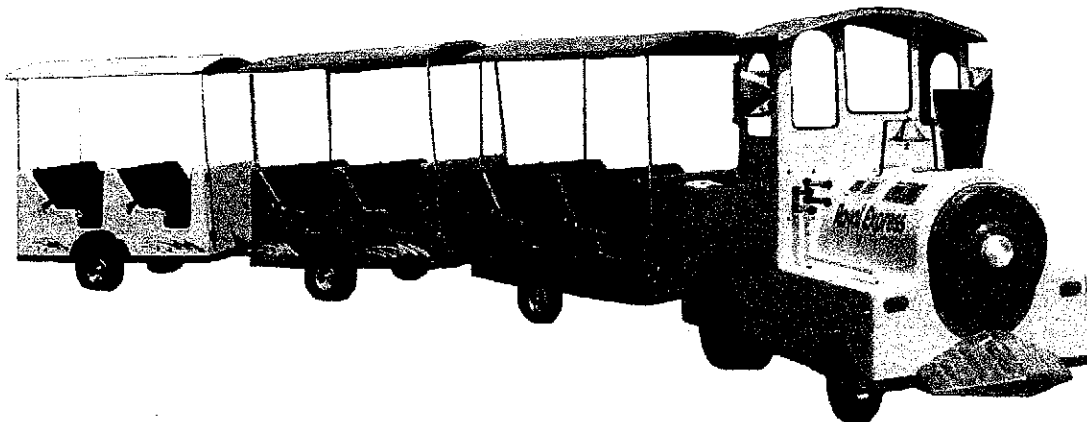

Royal Train Rides, Inc.  
181 Heckel Street  
Belleville, NJ 07109

Tel: (973) 759-2335      Fax: (973) 759-2746

## Table of Contents

1 – Introduction	
general overview of product and intended use	page 3
notice to purchaser - limited warranty	page 3
product capacity and specifications	page 4
owners information and responsibility	page 5
2 – Set-up	
assembly of unit	page 6
connection of coach	page 6
top – raising and lowering	page 7
3 – Operation	
general operation	page 8
slope operation	page 9
daily operation checklist	page 10
operating instructions	page 12
safety rules for operators	page 13
4- Care and maintenance	
drive unit and towed coach	page 14

### Note:

This manual was developed in accordance with NJDCA guidelines for a Portable Amusement Ride. Reference ASTM F770-93 & F853-98.

Your state rules and regulations governing portable amusement rides may be different. Check with your State or locality prior to operation.

Royal Train Rides, Inc. grants to the purchaser of this portable amusement ride the ability to reproduce this manual in part or in its entirety for the sole benefit of operation and maintenance of this portable amusement ride. We strongly encourage you to keep a copy of this manual on file in your office as well as with this portable amusement ride at all times. We also encourage you to photocopy and utilize the provided daily check list for each and every day of operation.

© 2008 by Royal Train Rides, Inc. All Rights Reserved

## 1- Introduction

The Royal Express is manufactured and sold by Royal Train Rides Inc. This portable amusement ride is comprised of (1) drive unit coupled to (4) towed coaches maximum. This amusement is a slow speed ride for the enjoyment of children and adults. The rider capacity of the Royal Express is (4) adults or (6) children per coach. The minimum height requirement for children riding without being accompanied by an adult is 30". The maximum rider height allowed is 72". The riders are safely enclosed in a fiberglass body and are restrained with seat lap belts. Riders enter and exit a stopped ride at a designated location. All items required to operate the Royal Express amusement ride are included.

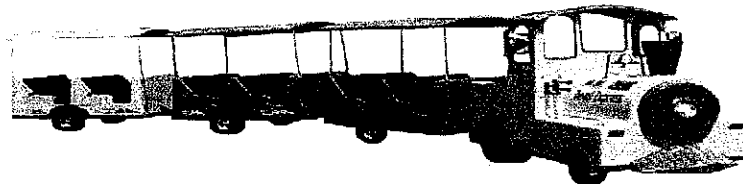

The Royal Express was designed to be operated on flat and level ground, i.e. **level grade only**. It is not intended for use on hills, inclines, slopes, sand or any other unstable terrain. It is also not intended for use on roadways or anywhere motorized vehicles are in operation.

### NOTICE TO PURCHASER – 1 YEAR LIMITED WARRANTY

Royal Train Rides Inc. warrants to the original purchaser that this amusement ride shall be free from defects in material and workmanship under normal use and service for a period of **One (1) year from the date of purchase**; however, this warranty does not cover the drive unit (complete) as the companies that manufacture these items furnish their own warranties and provide service through their authorized field service facilities. For additional information, see the warranties covering these units supplied with your amusement ride.

Subject to the terms and conditions noted in this **Limited Warranty**, we shall, at our option, repair or replace at no cost to the original purchaser any part covered by this **Limited Warranty** during the applicable warranty period. Transportation charges on parts submitted for repair or replacement under this **Limited Warranty** must be borne by the purchaser. No parts will be accepted for return without an approved Return Parts Authorization generated by the Royal Train Rides Inc customer service department.

This Royal Train Rides Inc **One (1) year Limited Warranty** is your exclusive remedy; however, this warranty is void or does not apply to any unit that has been tampered with, altered, misused, or abused. Your warranty does not cover minor mechanical adjustments which are not due to any defect in material or workmanship. All repair, maintenance, and upkeep are the responsibility of the owner of the amusement ride.

This **Limited Warranty** is effective for the time period stated above and subject to the conditions provided for in this policy. **There is no other Express Warranty. Implied warranties, including those of merchantability and fitness for a particular purpose are limited to One (1) year from purchase, or to the extent permitted by law; any and all implied warranties are excluded. Liability for consequential damages under any and all warranties are excluded to the extent exclusion is permitted by law.** Some states do not allow limitations on how long an implied warranty lasts, and some states do not allow the exclusion or limitation of incidental or consequential damages, so the above limitation and exclusion may not apply to you. This warranty gives you specific legal rights and you may also have other rights which vary from state to state.

# ROYAL EXPRESS

## **Locomotive:**

Body Length - 6'  
Hitch Length - 1' (1-7/8" coupler)  
Width - 43"  
Height - 72"  
Weight - 600 Lbs.  
Body - Fiberglass  
Tractor Unit - Gas Drive or Electric Drive  
Train Whistle - Manually Operated Air

## **Coaches:**

Body Length - 5'  
Hitch Length - 1' on each end (except cabooses) (1-7/8 coupler)  
Width - 43"  
Height - 72" with tops extended  
Weight - 250 Lbs.  
Capacity - 6 children or 4 adults per coach (650 lb. Total Max Per Coach)  
Frame - Welded Steel Tubing  
Body - Fiberglass  
Wheels - 15 x 600 - 6 turf tires on aluminum rims with sealed ball bearings

## **Royal Express Set Up:**

Over all length of train - 28'

Turning Radius - 16' - 18'

Tows up to 4 Coaches Maximum

"Recommended use Level Grade Only"

For Mobile Operators the Royal Express Transports on a 8' x 16' Deck Over Trailer or Cross loaded on a 6.5' x 16' Standard Landscape Trailer

## **Shipping Size and Weight**

**Boxed for shipping** - 1 Engine Create 48" x 86" x 76" @ 800 Lbs.  
3 Coach Creates 48" x 86" x 58" @ 400 Lbs. each

# ROYAL EXPRESS

## **Warning!**

Failure to follow these instructions may result in serious or fatal injury to the operator and passengers or cause damage to the amusement ride.

### **OWNERS INFORMATION:**

This manual is written for several different models. Some features and options may not be on your specific unit. These instructions are written for a person with some mechanical ability. Like most service and operation manuals, not all steps are described. Steps on how to loosen or tighten fasteners are steps anyone can follow with some mechanical ability. Read and follow these instructions before you use the unit.

### **KNOW YOUR PRODUCT:**

If you understand the unit and how the unit operates, you will get the best performance and your customers will have an enjoyable and safe experience. As you read this manual, compare the illustrations to the unit. Learn the location and the function of the controls. To help prevent an accident, follow the operating instructions and the safety rules. Keep this manual for future reference.

## **Warning!**

The engine exhaust from this product contains chemicals known to the State of California to cause cancer, birth defects or other reproductive harm.

## **Warning!**

Battery posts, terminals and related accessories contain lead and lead compounds, chemicals known to the State of California to cause cancer, birth defects or other reproductive harm.

### **RESPONSIBILITY OF THE OWNER, DRIVER AND OPERATOR**

The responsibility of the owner, driver and operator is to follow the instructions below.

1. Carefully read and follow the rules of safe operation.
2. Follow the assembly instructions (if assembly is required).
3. Inspect the unit before each use.
4. Make sure the operator and driver of the unit know how to correctly use all features.
5. Operate the unit only with guards, shields, lap seat belts and other safety items in place and working correctly.
6. Correctly adjust the unit.
7. Service the unit only with authorized or approved replacement parts.
8. Complete all maintenance on the unit.

#### **Environmental Awareness:**

Do not fill the engine's fuel tank when customers are located in the area or are seated in coach.

Do not fill the engine's fuel tank completely full.

Do not spill fuel or oil.

Use only approved gasoline containers for storage.

Follow the drive unit (engine) manufacturer's recommendations for fuel and oil type.

Tune-up the engine and service the air cleaner regularly for efficient and clean use.

Dispose of used oil, fuel and batteries properly.

## **2-Set up**

### **ASSEMBLY OF THE ROYAL EXPRESS:**

The assembly of the Royal Express is comprised of connecting the towed coaches to the drive unit as well as the raising and lowering of the fiberglass coach top.

#### **Hitch connection:**

The connection between the coach and drive unit is accomplished by using a trailer style ball and ball hitch. Like all trailer hitches, the ball is retained on the lead vehicle and the hitch is located on the towed vehicle.

Prior to connection, make sure that the nut retaining the ball to its mounting bracket as well as the bolts on the hitch are tight and secure.

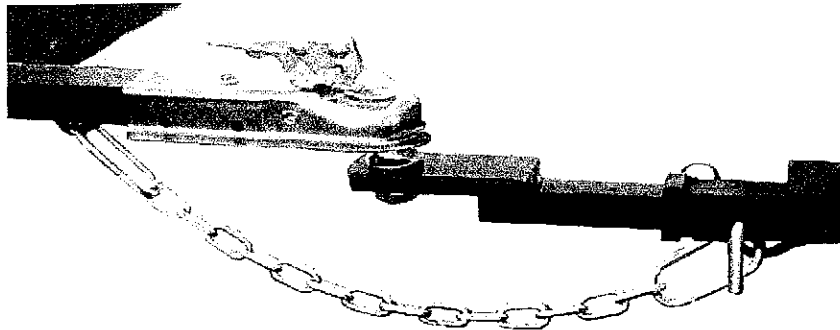

To connect the hitch to the ball, the lever located on the top of the hitch must be pivoted upward. This motion will release the inner locking tongue, which is inside the hitch. Place the hitch over top of the ball and then lower the hitch onto the ball. Pivot the hitch lever downward. This motion will extend the tongue under the ball and complete the connection.

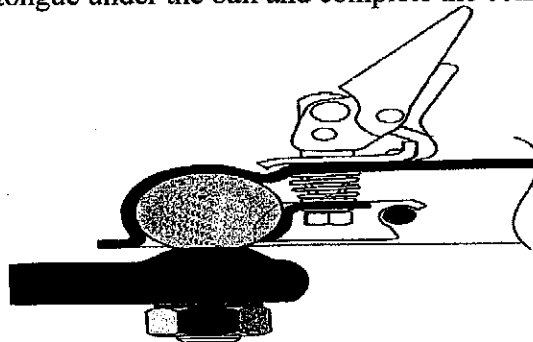

Visually verify that the tongue is extended under the ball and then install the safety pin/clip thru the release lever. Connect safety chain from trailer hitch to the mounting bracket of the ball hitch.

**Coach Top – raising and lowering:**

Each Royal Express coach is shipped with the coach top in a lowered position. When transporting the Royal Express to and from events on an open trailer, the roof should be placed in the lowered position. The ride should never be operated with the top in the lowered position. Before and after raising and lowering the top, insure the hitch pins are installed and locked in place as shown below.

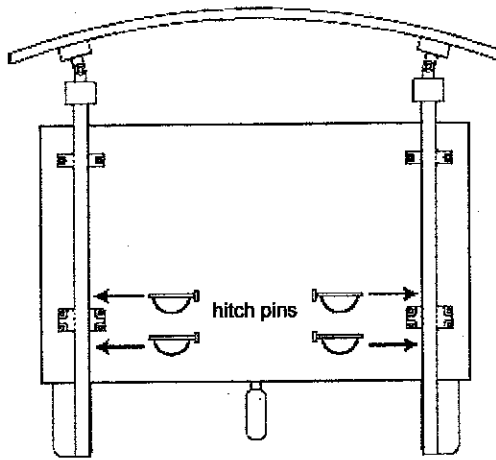

**LOWERED POSITON**  
**(Transport only)**

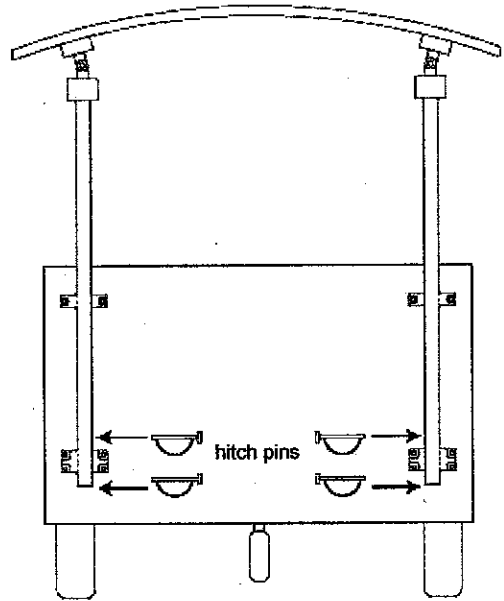

**RAISED POSITION**

### **3 – Operation**

#### **IMPORTANT:**

The driver should be instructed and familiar with all operating procedures and instructions BEFORE accepting passengers.

The driver should perform the pre-operation inspection check list daily BEFORE accepting passengers as well as perform the inspections during daily operational break time. If the unit is transported to multiple sites on a single day, the operator should perform the pre-operation check list BEFORE accepting passengers at each new site.

When the unit is not in operation, and the driver is not seated or positioned at the drive unit, the engine should be turned off, the key removed, and parking brake engaged.

The driver should always be familiar and aware of his surroundings, passengers, and environmental conditions. If any of these are deemed a concern or become unsafe, the driver should cease operation of the unit.

#### **GENERAL OPERATION:**

Read, understand and follow all instructions in this manual, on the unit, the engine, and on any attachments before operating.

Only allow responsible adults, who are familiar with the instructions and who have been trained in the operation of this unit, to operate this unit.

Clear the operating area of objects such as rocks, toys, debris, ropes and wires, electrical extension cords, etc., which could become entangled in the drive unit or towed vehicles or could cause a trip hazard with riders entering or exiting the unit.

Operate the unit in an area that is clear of other vehicles, people, pets or other moving objects.

Watch for traffic when operating near or crossing roadways.

Operate the unit in a consistent and repeatable manner. Do not change momentum quickly, do not swerve or zig-zag. Slow down before turning.

Never leave a unit unattended with the engine running.

Turn off all accessories or power units when transporting or not in use.

Operate only in daylight or good artificial light.

Do not operate the unit in the rain, snow, fog, or any electrical and lightening storms.

Do not operate the unit while under the influence of alcohol or drugs or when very tired.

Do not operate this unit if you are taking drugs or other medication(s) which can cause drowsiness or affect your ability to operate this unit.

Do not operate this unit if you are mentally or physically unable to operate this unit safely.



## SLOPE OPERATION:

### **Warning!**

**Do not operate this amusement ride on slopes, inclines or hills.**



This unit is **recommended for Level Grade Only**. Slopes and rough terrain are major factors related to loss-of-control and tip-over accidents, which can result in severe injury or death. **ALL slopes require extra caution.**

### **Warning!**

If during operation on **Level Grade Only**, the operator discovers he/she has entered an area containing a slope or is situated on a slope, the following guideline should be used.

- 1 - Apply PARKING BRAKE and turn unit off – remove key.**
- 2 - Help passengers to exit coach, and escort passengers to safe location away from disabled unit.**
- 3 - If needed, escort all passengers to planned start/stop location.**



The following guidelines and recommendations are to be used to move an **unloaded (no passengers)** Royal Express portable amusement ride from a slope, hill, or incline.

- Drive up and down slopes, not across.
- Do not turn on slopes.
- Remove obstacles such as rocks, tree limbs, debris, etc...
- Watch for holes, ruts or bumps. Uneven terrain could overturn the unit. Tall grass can hide obstacles.
- Use slow speed on slopes. Keep all movement on the slopes slow and gradual. Do not make sudden changes in speed and direction.
- Avoid starting or stopping on a slope. If tires lose traction, and forward motion can not resume, stop all operation of unit.
- Do not drive along ditches or embankments. A wheel over the edge or an edge caving in could cause a sudden overturn and an injury or death.
- Do not operate when reduced traction is possible.

# Royal Express Daily Operation Check List

Date: \_\_\_\_\_

checklist page 1 of 2

**Drive Unit**

Check fluid levels of gas engine and gas tank (if equipped)	<input type="checkbox"/>	
Check for proper functioning of exhaust and muffler (if equipped)	<input type="checkbox"/>	
Check for fluid leaks at gas engine, gas tank, gas line (if equipped) and at transaxle	<input type="checkbox"/>	
Check battery terminal connections as well as battery(s) being properly secured	<input type="checkbox"/>	
Check for properly charged and fully charged batteries	<input type="checkbox"/>	
Disconnect and store charger power cord (if equipped)	<input type="checkbox"/>	
Check electrical connections at motor (if equipped)	<input type="checkbox"/>	
Verify parking brake function engage and disengage	<input type="checkbox"/>	
Verify pedal braking function engage and disengage	<input type="checkbox"/>	
Check for proper steering function and smooth operation	<input type="checkbox"/>	
Check for proper motion control in forward and reverse direction	<input type="checkbox"/>	
Check function of all other controls	<input type="checkbox"/>	

**Tires and Wheels**

Check for proper inflation of all tires	<input type="checkbox"/>	
Check condition of tires inspect for gouges, punctures and excessive wear	<input type="checkbox"/>	
Check wheel bearings for excessive play	<input type="checkbox"/>	
Check coach rear dolly wheel for smooth motion in swivel and rotation	<input type="checkbox"/>	

**Steering**

Check for proper range of motion and smooth operation	<input type="checkbox"/>	
Check for loose fittings and excessive play	<input type="checkbox"/>	

Inspection Performed by: \_\_\_\_\_

Repairs Performed by: \_\_\_\_\_

# Royal Express

## Daily Operation Check List

Date: \_\_\_\_\_

checklist page 2 of 2

### Braking

Verify parking brake function effective and smooth	<input type="checkbox"/>	_____
Verify pedal braking function effective and smooth	<input type="checkbox"/>	_____

### Safety Devices

Verify all seat belts are in proper working condition	<input type="checkbox"/>	_____
Check for rips, tears or punctures to seating surface	<input type="checkbox"/>	_____
Check operation on all audible warning devices (if equipped)	<input type="checkbox"/>	_____
Verify all warning and caution labels are in place and readable	<input type="checkbox"/>	_____

### Ball Hitch Coupler

Check condition of coupler, ball, hitch, latch and retaining clip	<input type="checkbox"/>	_____
Verify latching operation of coupler	<input type="checkbox"/>	_____
Inspect for excessive wear of coupler latch and ball	<input type="checkbox"/>	_____
Inspect mounting and retaining nuts/bolts and wire harness retaining strap	<input type="checkbox"/>	_____

### Fiberglass Body

Verify all safety devices, shrouds and guards are in place and operating properly	<input type="checkbox"/>	_____
Check for loose hardware, fittings, decals, cushions, and flooring	<input type="checkbox"/>	_____
Clean and clear floor and seating area inspect body for any damage	<input type="checkbox"/>	_____
Verify coach top hitch pins are installed and latched closed.	<input type="checkbox"/>	_____

Inspection Performed by: \_\_\_\_\_

Repairs Performed by: \_\_\_\_\_

## **OPERATING INSTRUCTIONS**

1. Be sure that the operator is instructed regarding operation of the unit before operation begins.
2. Instruct all passengers to keep their head, hands and legs inside the coach. Standing while riding is not permitted.
3. **OPERATE RIDE ON LEVEL GRADE ONLY**
4. Avoid excessive speed on all terrain.
5. No "zig-zagging" of unit, excessive weaving, or other potentially dangerous driving.
6. Slow the Royal Express down before going into turns. Stop the Royal Express in a straight line for loading and unloading.
7. Avoid ditches, holes and other difficult terrain which could unbalance the Royal Express.
8. Distribute the weight of adults and children evenly. See the specification sheet for maximum occupants and loads.
9. Any rider behaving in a rowdy or dangerous fashion should be dismissed for the ride immediately.
10. Keep passengers and bystanders away from the drive unit. Turn the engine off during breaks and remove the key.
11. Check all seat belts before departing.
12. When transporting the Royal Express on an open trailer, be sure to properly secure the drive unit and coaches to the trailer and secure all loose items. The roof should be placed in the lowered position for transportation.

**REMEMBER – SAFETY FIRST..... HAVE FUN!**

## **SAFETY RULES FOR AMUSEMENT RIDE OPERATORS**

1. Be sure you understand the use and function of controls, signal systems and safety devices.
2. Be familiar with the ride manufactures manual.
3. Inspect and test the entire ride before each operating period.
4. Stop the ride when any unusual noise or condition develops. Do not operate the ride until your supervisor has inspected and repaired the ride.
5. Remain in control of the ride at all times. Never allow an unauthorized person to operate this ride.
6. Do not operate this ride at unsafe speeds or load beyond its capacity.
7. Be alert when the ride is operating for an emergency stop.
8. Be aware of changing weather conditions. Do not operate this ride during high winds or electrical storms.
9. Persons that appear to be ill or under the influence of alcohol or drugs should not be allowed on the ride.
10. Be sure the riders fit the ride. Children should meet the minimum size requirements. Adults must fit safely and comfortably in the seat.
11. Safety belts, lap chains or safety bars must be properly secured before starting the ride.
12. Patrons waiting for the next ride must be kept outside of the fence or away from the moving ride.
13. Ensure patrons remain seated until the ride comes to a complete stop.
14. Know the location of the closes First Aide Station and fire extinguisher.
15. Any incident, no matter how small, must be reported to the supervisor at once.

**TAKE PRIDE IN OPERATING SAFELY**

## **4 – Care and Maintenance:**

1. Refer to the owner's manual of the drive unit for specific instruction for that unit. Be familiar with maintenance: oil change, filter, plugs, battery charging requirements, etc. Follow a regular maintenance schedule for the drive unit to keep it running in optimum condition. Keep tires properly inflated.

2. Regularly tighten all nuts and bolts as the vibration of use may loosen them.

3. Wash only with mild soapy water and a soft cloth. Do not scrub pin-striping, logos, decals or fiberglass.

Caution: Avoid wetting the engine, electronic controls and connectors or any other component of the drive system or safety control device.  
Water saturation can cause failures.

4. Marina and boat supply companies normally sell an excellent quality spray wax made specifically for fiberglass. Check your local boat or auto supply store.

5. Frequent visual inspections of the Royal Express will keep small problems from becoming big trouble.